

THE TRANSVERSE SPREAD OF THE "X" MAY VARY ACCORDING TO LANE WIDTH. A THREE LANE ROADWAY SHOULD BE MARKED WITH A CENTER LINE FOR TWO-LANE OPERATION ON THE APPROACH TO A CROSSING. ON A FOUR-LANE ROAD THE TRANSVERSE BANDS SHOULD EXTEND ACROSS THE TWO RIGHT-HAND LANES ONLY TO THE CENTER LINE, AND A 10-FOOT "X" SHOULD BE CENTERED IN THE RIGHT HALF OF THE PAVEMENT. ON ROADWAYS WHERE ONE HALF THE PAVEMENT WIDTH (OR THE WIDTH ASSIGNED TO TRAFFIC IN ONE DIRECTION) EXCEEDS 30 FEET, TWO OR MORE OF THE RXR SYMBOLS SHOULD BE SYMMETRICALLY PLACED SIDE BY SIDE ON THE RIGHT HALF OF THE PAVEMENT.

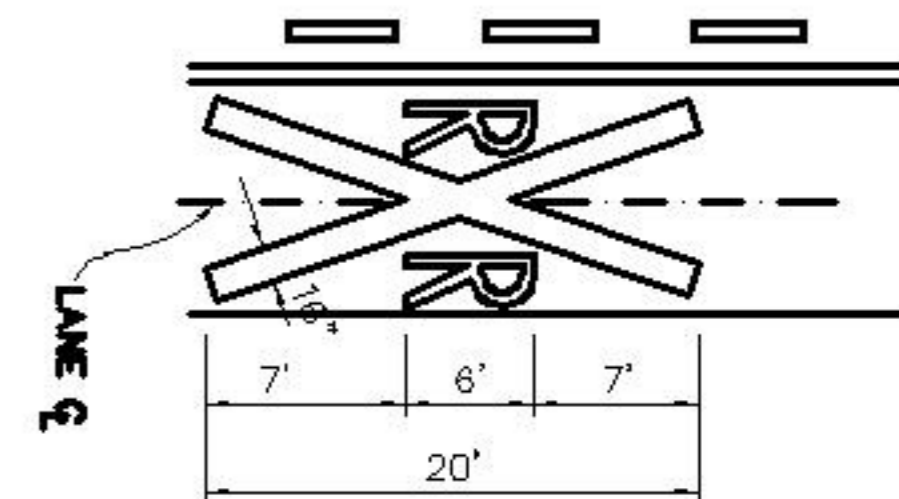
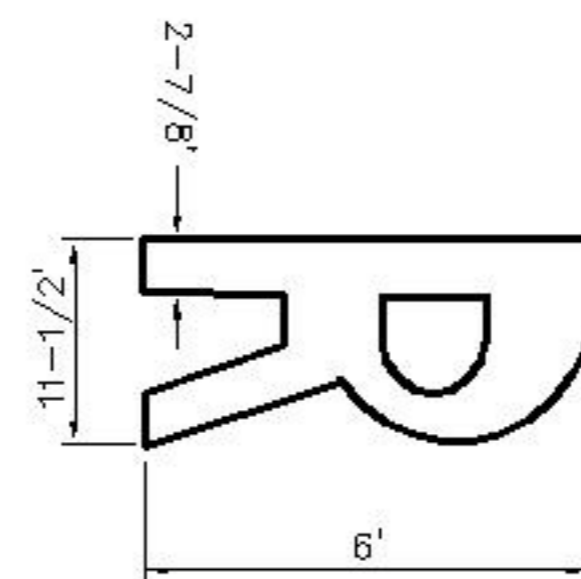

REVISED	F.B.	PG.	DATE: 7-30-85
			SCALE: NONE
			DRAWN BY: P.N.R.
			CHECKED BY: DKL
			CITY ENGINEER: DEC

STANDARD DETAIL

STANDARD PAVEMENT MARKINGS AT RAILROAD-HIGHWAY GRADE CROSSINGS

OFFICE OF THE
CITY ENGINEER
GASTONIA, N.C.

FILE NO.

71E-16